



INTUITIVE HUMAN INTERFACE SOLUTIONS

# CAN-bus Keypads for Off-Highway Vehicles

- Five standard keypad form factors available
- J1939 and CANopen versions
- Dimmable LED indicators and legends
- Sealed to IP67
- Vibration and impact resistant
- Operating temp: -40°C to +85°C
- Long life: 1,000,000 cycles per key
- Support for multiple key press combinations
- Designed for 12/24 volt systems
- Custom legends and configurations available



## 3K SERIES KEYPADS CUSTOM OPTIONS

Contact Grayhill to build your custom part number

- Custom keytop legends
- Up to 3 LED indicators per key
- Indicator colors:  
Red, Amber, Green, Blue
- Custom backlight colors:  
Red, Amber, Green
- Factory configured parameters

## Your Experts in Cab Controls

Grayhill specializes in the design, development and production of human interface controls, including:

- Cab user interface design
- Customized control panels
- CAN-bus interface devices

[www.grayhill.com](http://www.grayhill.com)

Agriculture



Construction



**DIMENSIONS** in inches (and millimeters)  
ISO Symbols shown in dimensional drawings

### 4 x 5 Keypad

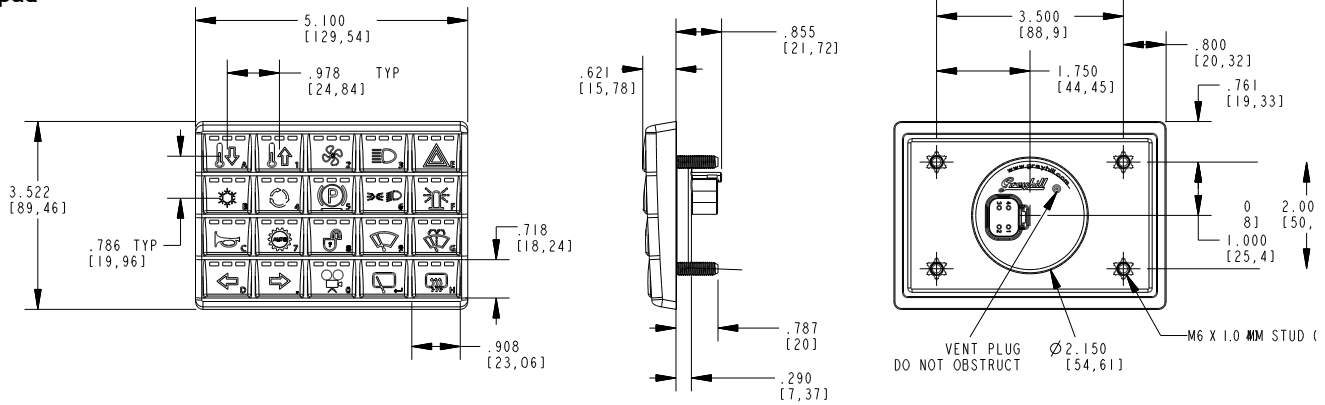

### 3 x 5 Keypad

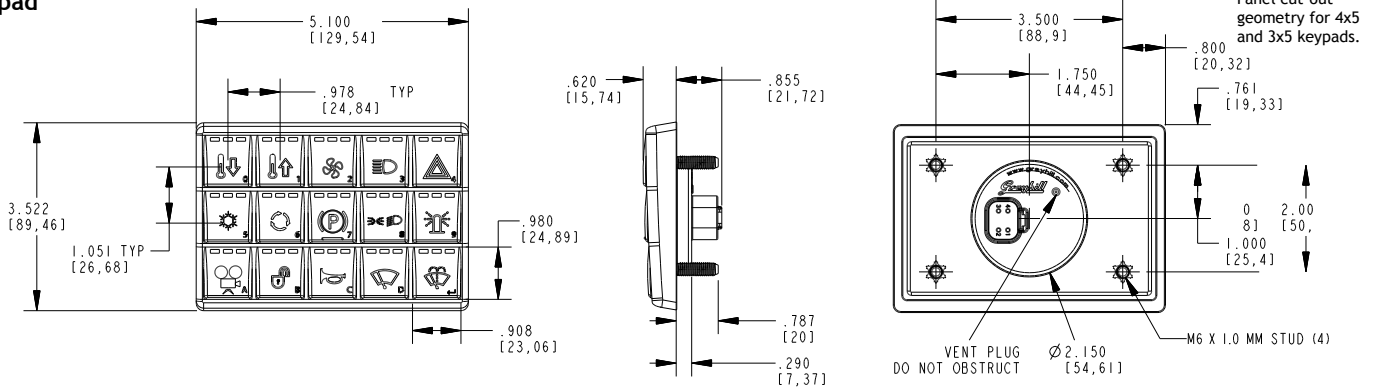

### STANDARD LEGEND SETS



3K115-3RC3AG



3K112-4RC3AG



3K108-4RC3AG



3K208-4RC3AG



3K120-4RC3AG



3K108-2RC3AG



3K208-2RC3AG

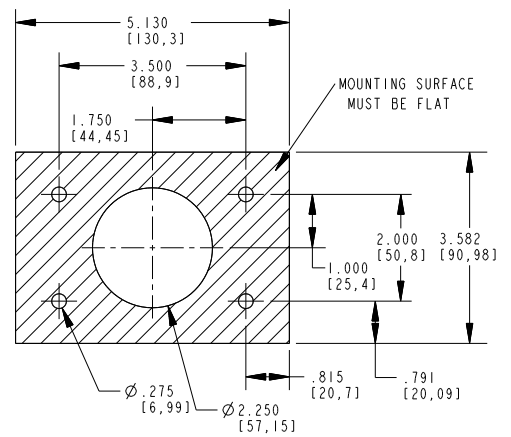

### CONNECTION

4 pin Deutsch DT Connector.  
Power with 8V to 32V vehicle type inputs.

Pin 4: CAN L  
Pin 3: CAN H



Pin 1: Power  
Pin 2: Ground

**DIMENSIONS** in inches (and millimeters)

**4 x 3 Keypad**

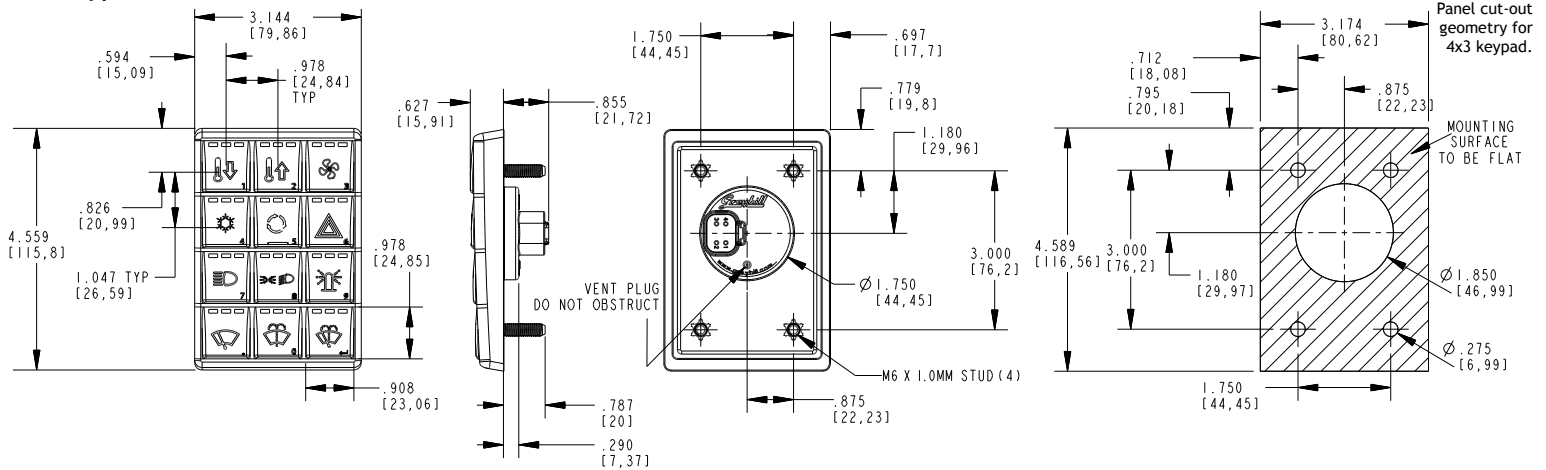

**4 x 2 Keypad**

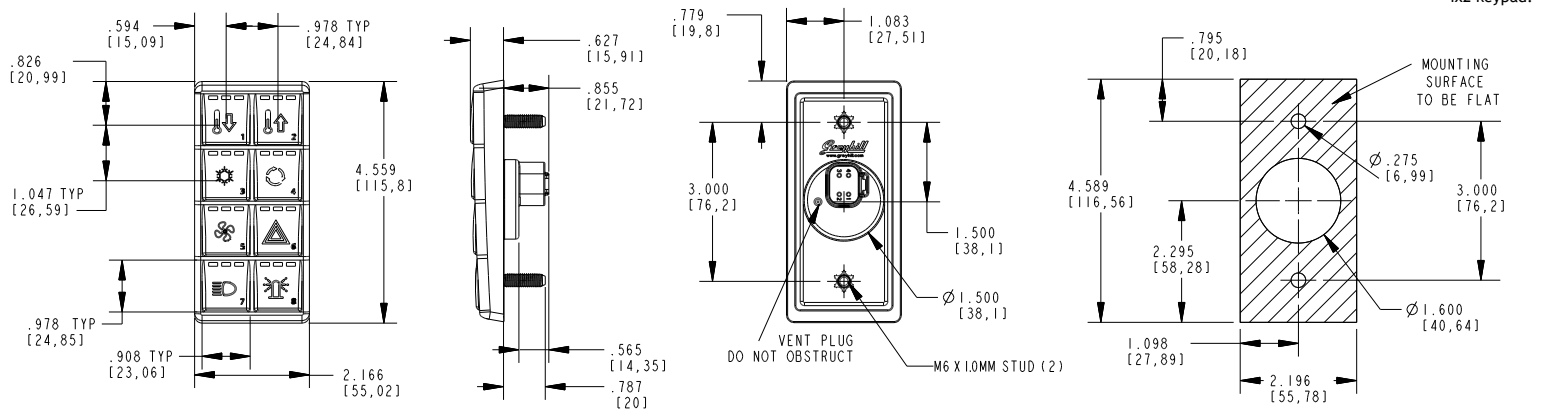

**2 x 4 Keypad**

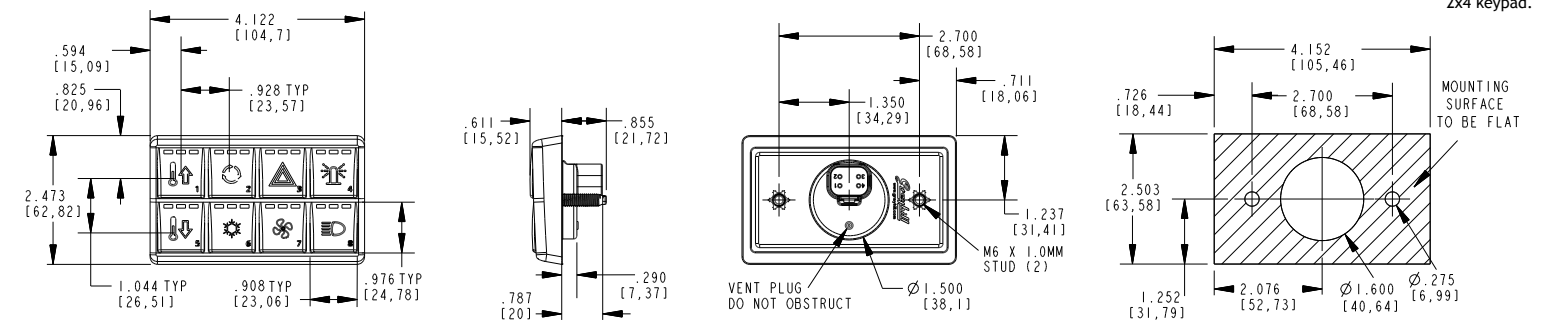

**ORDERING INFORMATION**

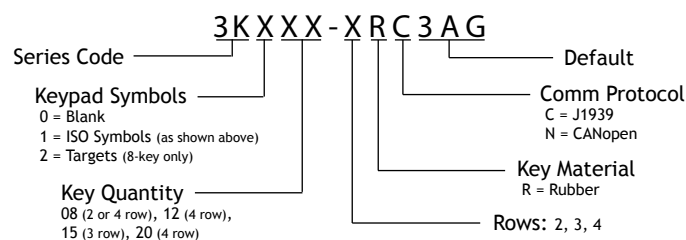

**CUSTOMIZATION OPTIONS**

- Contact Grayhill to build your custom part number
- Custom keytop legends
  - Up to 3 LED indicators per key
  - Indicator colors: Red, Amber, Green, Blue
  - Custom backlight colors: Red, Amber, Green
  - Factory configured parameters



INTUITIVE HUMAN INTERFACE SOLUTIONS

**ENVIRONMENTAL TESTING STANDARDS**

Operating temperature, High	ANSI/SAE EP455 5.1.1 Level 2	+85°C for 11 hours
Operating temperature, Low	ANSI/SAE EP455 5.1.1 Level 2	-40°C for 4 hours
Storage Temperature, High	ANSI/SAE EP455 5.1.2 Level 2	+85°C 4 hours
Storage Temperature, Low	ANSI/SAE EP455 5.1.2 Level 2	-40°C 4 hours
Thermal Shock	ANSI/SAE EP455 5.1.3	-40°C to 70°C at a rate of 4°C/min (1 hour at extremes)
Altitude (Barometric Pressure)	ANSI/SAE EP455 5.2	101.3kPa to 18.6kPa
Sand and Dust	ANSI/SAE EP455 5.3	24 hours with 0.88g/m3
Solar Radiation	ANSI/SAE EP455 5.4	43 to 75W/m2 UV Radiation (280 to 400nm wavelength) for 300h
Wash Down	ANSI/SAE EP455 5.6 Level 2	375 kPa and 8.3 L/min for 10 minutes @ 15°C Water temp
Ingress Protection	IP67	1 meter submersion for 30 minutes
Humidity	ANSI/SAE EP455 5.13	96% Humidity at 35°C for 240 hours.
Salt Fog	ANSI/SAE EP455 5.9	5% aqueous solution of NaCl @ 35°C and a pH between 6.5 and 7.2 for 48 hours
Chemical resistance (Resistance to Solvents)	ISO 16750-5 EP 455 (5.8.2)	
Thermal Cycling (Change of Temperature)	ISO 16750-4	-40° to 85°C 2 hours at extremes change rate = 1°C/min (8 hours) repeat for 30 cycles.

**ELECTROMAGNETIC COMPATIBILITY STANDARDS**

ESD	ANSI/SAE EP455 5.12	+/- 25kV for 10 pulses, 5 of each polarity
Radiated Immunity	ISO14982 6.6	10MHz-1000MHz Range 48mA Bulk Current Injection 100V/m
Conducted Emissions	SAE J1113-41, Control/Signal lines only	Class 3 for 3K120-4RC3AG, 3K108-2RC3AG. Class 4 for 3K115-3RC3AG, 3K112-4RC3AG, 3K108-4RC3AG
Broadband Radiated Emissions	ISO14982 6.4	64dB to 54dB, 30MHz-75MHz (linearly decreases) 54dB to 65dB, 75MHz-400MHz (linearly increases) 65dB, 400MHz-1000MHz

**PHYSICAL TESTING STANDARDS**

Vibration, Random	ANSI/SAE EP455 5.15.1	2 hours each axis @ 52.4 m/s2 RMS overall acceleration and spectral power density of 2m2/s3 from 50Hz to 2000Hz
Vibration, Sinusoidal	ANSI/SAE EP455 5.15.2	A logarithmic sweep from 10Hz to 2000Hz to 10Hz over a period of 20 minutes for 4 hours in each of 3 orthogonal axes with amplitude of 1.5mm from 10Hz to 40Hz and a constant acceleration of 35m/s2 RMS from 40Hz to 2000Hz.
Shock / Crash Safety	ANSI/SAE EP455 5.14	A single 11ms half sine pulse of 490 m/s2 in 3 perpendicular axes.
Drop	ANSI/SAE EP455 5.14.2 Level 1	Drop component 400 mm onto a hardwood benchtop on all practical edges.
Shipping integrity	International Safe Transit Agency procedure 3A	

**ELECTRICAL PERFORMANCE STANDARDS**

Maximum load	ANSI/SAE EP455 5.1.1 Level 2	-40°C 4 hours +85°C for 11 hours max load applied
Jump start forward voltage	ISO 16750-2	36V for 60 minutes
Jump start reverse voltage	ISO 16750-2	-36V for 60 minutes
Short circuit protection	ISO 16750-2	All outputs to ground for 60s
Reverse polarity protection	ISO 16750-2	28V for 60s
Starting profile	ISO 16750-2	12V class B, 24V class A
Battery-less operation	ANSI/SAE EP455 5.11.3 Level 2	Apply 6+12.6sin(2*pi*f*t) f is swept from 500Hz to 1.5kHz 5min
Load dump	ISO 7637-2 Test Pulse 5b	Class A
Switching spikes – negative	ISO 7637-2 Test Pulse 3a	Class A
Switching spikes – positive	ISO 7637-2 Test Pulse 3b	Class A
Wire harness inductance	ISO 7637-2 Test Pulse 2a and 2b	Class A
+/- inductive load pulse	ANSI/SAE EP455 5.11.4	14-300e^(-t/.001)V 1Hz for 300 cycles
+/- mutual coupling	ANSI/SAE EP455 5.11.6 Level 2	14+200e^(-t/14x10^-6)V 1Hz for 300 cycles
Alternator field decay	ANSI/SAE EP455 5.11.2	Class A

**CE COMPLIANCE**

Agriculture and Forestry Machinery EMC	ISO 14982	ESA
Construction Machinery EMC	EN 13309:2000	ESA

Contact Grayhill or your local Grayhill sales representative for more information.

Grayhill, Inc.  
561 Hillgrove Avenue  
LaGrange, Illinois 60525  
phone: (708) 354-1040  
fax: (708) 354-2820

Bulletin 1123  
Rev 04/11

www.grayhill.com

