

## NETWORK INTERFACES

### OpenLT™ (Optomux)

#### FEATURES

- Each Unit Controls/Monitors up to 32 Analog and/or Digital I/O using OpenLine® Modules
- Executes On-Board Programs Created With Borland C
- Network up to 64 OpenLTs per Host Serial Port, Spanning as Much as 4000 Feet
- Communicate Over RS422 /485 at Speeds from 9600 Baud to 115.2 KB
- 100% Optomux Compatible, With Expanded Command Set
- I/O Update Rates of 500 µSec per 32 Digital I/O, and 2 mS per Analog Input or 2 Analog Outputs
- 64-Bit Floating Point Math
- DIN Rail or Panel Mountable
- CE Certified

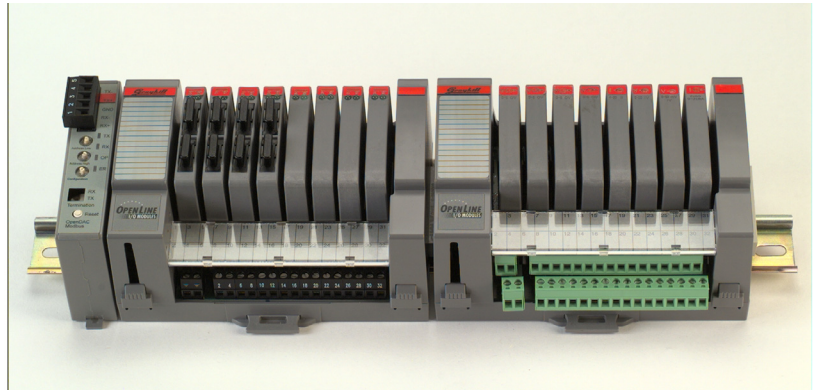

OPENLT® UNIT ON OPENDAC® SYSTEM

#### APPLICATIONS

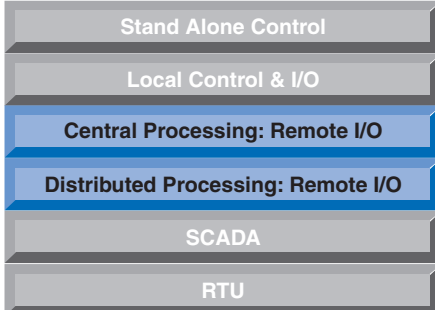

#### GENERAL DESCRIPTION

The OpenLT™ Optomux™ controller is a remote slave that responds to Optomux™ commands from the master or host PC. The 72-OPT-4100 version has memory for Embedded Control Programs (ECPs) which are control or data acquisition routines which run locally on the OpenLT™ and off-load some responsibilities from the host. ECP routines written for MicroDAC can be easily transferred to OpenLT™ and vice versa. By combining MicroDAC, OpenLT™ and ProMux® the cost/performance of a distributed control or data acquisition network is optimized for price and performance.

#### ANALOG & DIGITAL I/O

OpenLT® connects directly to one or two OpenLine® racks (part number 70LRCK16-48). Any combination of OpenLine® analog and digital I/O modules may be used. OpenLTs™ can be networked to a host PC which execute programs that monitor the input signals and control the outputs. In addition to simple ON/OFF instructions, commands are included which permit you to:

- Sample analog signals at 2 mS per input
- Flag values above or below prescribed levels
- Capture min/max values
- Calculate the average input signal levels
- Provide linearized thermocouple and RTD temperature values
- Determine the width of input pulses
- Count pulses at frequencies up to 1000Hz
- Detect rising or falling edges
- Latch momentary input events
- Set the level of analog outputs
- Provide delayed-on or delayed-off outputs

#### COMMUNICATIONS

The host computer and OpenLT(s)™ communicate serially over one or two pair of twisted wires per RS-422/485 in a multi-drop configuration. They use Optomux™ ASCII format to code the command and the response messages. Application programs running on the host computer issue commands and then await responses from the OpenLT™. The communications speed is selectable between 9.6 and 115.2 KBaud. Each controller on the network is assigned a unique base address. The entire network can span 4000 feet. Diagnostic LEDs show traffic on the network.

#### EMBEDDED CONTROL PROGRAMS

By specifying OpenLT(s)® with the optional 64 KB of flash memory, you can develop and download C language programs to any of the networked controllers.

Even while an ECP is running on OpenLT®, any Optomux™ command it receives from the host will be processed as usual, which allows you to delegate some or all of the control and data acquisition responsibility from the host computer. This reduces communications time and improves system response.

For embedded or stand-alone applications, downloaded ECP routines can be initiated on power-up.

Libraries and the appropriate download utility are included with the ECP Programmers Manual.

#### SOFTWARE

Software drivers are available which simplify the task of interfacing host programs written in Visual Basic or C to the Optomux network. Sample programs, set-up and debug utilities are included on the disk with the drivers. Interface drivers for most third party software packages are available through their distributors. Our Optomux DDE Server dramatically simplifies data sharing between OpenLTs™ and Windows applications, such as Microsoft EXCEL (see Controller Software). Our DLL will assist you in building custom Windows Man-Machine Interfaces using Visual Basic, Visual C/C++, or Borland compilers.

**DIMENSIONS** In inches (and millimeters)

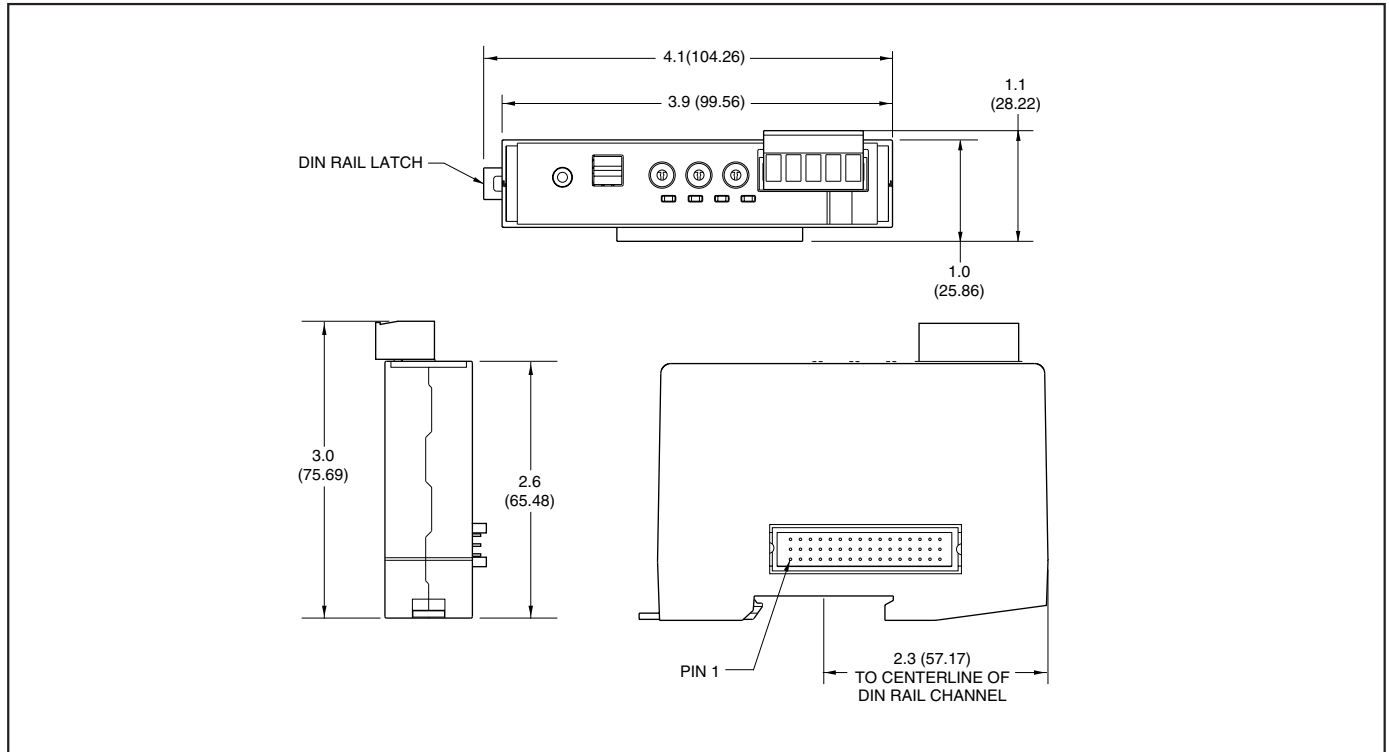

**SPECIFICATIONS**

**Power Supply:** 4.75 to 5.25 Vdc  
**Supply Current (less modules):** 300 mA max.  
**Operating Temperature:** 0 to 60°C  
**Humidity:** 95% non-condensing  
**Microprocessor:** V25 @ 10 MHz  
**Housing Material:** ABS/Polycarbonate blend  
**Connections:**  
 RS-422/485: 5 position pluggable terminal block  
 Rack: 48-pin Euro DIN (male)  
**Serial Data:**  
 Format: 10-Bit ASCII, 1 Start, 1 Stop, 8 Data  
 Integrity: Message Checksum or 4 Pass + CS  
**Range of Network:** Compliant with EIA/TIA RS485-A (1 standard load per controller). Operates in multi-drop mode. 64 DIP switch selectable addresses. May require RS485 repeaters for lengths over 4000 feet or more than 32 controllers. Consult factory for special configurations.

**ORDERING INFORMATION**

Part Number	Description
<b>OpenLT® Network Interface</b>	
<b>72-OPT-4000</b>	Analog/Digital OpenLT®
<b>72-OPT-4100</b>	Analog/Digital OpenLT® with 64K flash for C ECP storage
<b>OpenLT® User's Manuals and Software</b>	
<b>72-UMM-D</b>	Driver development and protocol definition (includes driver source code)
<b>72-UMM-DDE</b>	Optomux DDE server for Windows 3.1
<b>72-UMM-DLL</b>	Optomux DLL for Windows 3.1
<b>72-UMM-DLL32</b>	Optomux DLL for Windows 95/98/NT
<b>72-UMM-E</b>	C language ECP manual with libraries
<b>72-UMM-H</b>	Programmer's manual with Basic and C host drivers and examples
<b>72-UM-OOPT</b>	Hardware installation and setup. Includes setup and debug programs
<b>72-UOL</b>	OpenLine® configuration and product data
<b>7W-UM-MDL32</b>	Windows ECP download Utility
<b>Compatible Components</b>	
OpenDAC® I/O Racks Digital OpenLine® I/O Modules Analog OpenLine® I/O Modules Power Supplies	

**Available from your local authorized Grayhill Distributor.** For prices and discounts, contact your local sales office, an authorized Distributor or Grayhill.

OpenDAC® I/O System